



C B A 3 0 0 0

ALL - IN - ONE CIRCUIT BREAKER ANALYZER



[www.isatest.com](http://www.isatest.com)



## All - in - one circuit breaker analyzer

The ultimate all-in-one circuit breaker analyzer: safer, faster and more accurate than ever. It allows any timing test, motion and speed analysis, multiple contemporary static and dynamic contact resistance measurements, Both Sides Grounded (BSG) tests, Undervoltage condition test and more. All these functions are integrated in a single lightweight test case without the need of connecting additional external modules

- Faster: one single connection set up to perform automatically all possible Circuit Breaker tests
- Safer: Both Side Grounded feature without any additional external boxes/modules
- Fully configurable
- 3/6/9 static and dynamic contact resistance measurements – 200A DC output each
- Three phase first trip measurement
- 16 or 24 fully user configurable Main/PIR and auxiliary input contacts
- 2, 4 or 6 Open / Close coil commands
- 3 analog linear/rotary transducers and 3 digital transducers inputs for travel/ speed analysis
- 8 analog input measurements: battery voltage, motor current, pressure transducers and any other measurements
- Minimum voltage trip coil test, fully automatic
- On-screen control and test results evaluation
- TDMS software suite for results analysis, archiving and test report creation
- Library of standard test plans are available with the test set

### CBA 3000 - FRONT PANEL



CBA 3000 - BACK PANEL

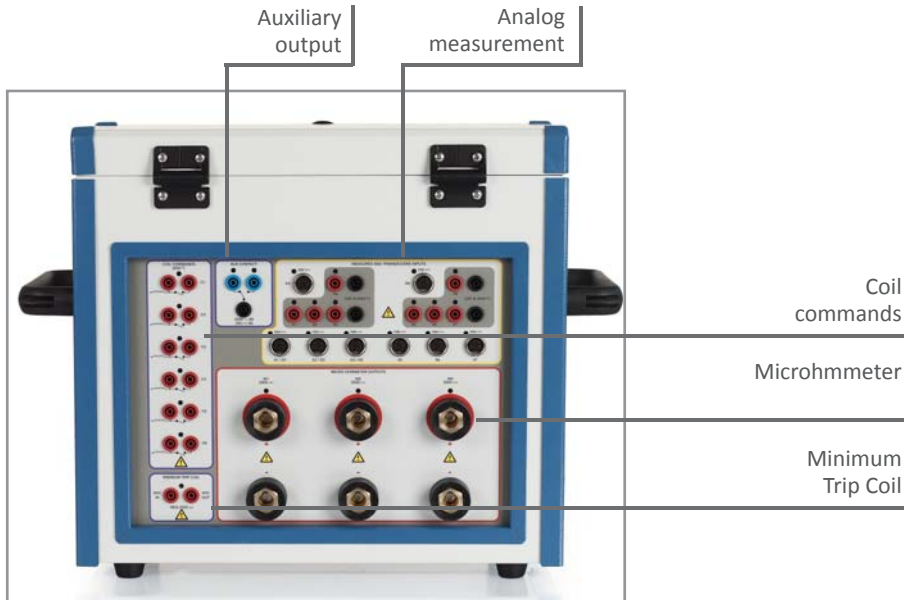

CBA 3000 - SIDE PANELS





## D E S C R I P T I O N

The all-in-one circuit breaker analyzer and micro-ohmmeter model CBA 3000 is a unique test set.

- When used as a Circuit Breaker Analyzer, it allows the off-line testing of MV and HV circuit breakers. The test set measures circuit breaker operation times as they are defined in the IEC standard 62271-100.

- CBA 3000 is also a **three/six /nine breaks micro-ohmmeter**, it allows measuring the Static Contact Resistance ( SCRM) of the circuit breaker contact and the Dynamic Contact Resistance (DCRM), that is how the breaker contacts resistances change while the breaker is closing or opening. This allows detecting hidden defects, that are otherwise impossible to be diagnosed.

### The instrument performs the following features:

- Test set control:** via large 7 " colour display. In this way it's possible to select the test plan, perform all tests, analyse the results, zoom in and out the graph. A number of function keys and keypad plus selection encoder give full control of the test set. USB and Ethernet interface for communication with the PC are provided.

Capability to transfer results directly to an USB pen drive.  
Huge recording capability: more than 256 Mb (typically 1000 results).

- All possible **Test Plans** are programmable. A Test Plan Editor is available in the test set while a Test Plan Library is supplied with the CBA 3000. The selected test plan includes all the operations that must be executed on a circuit breaker: Timing, Travel, Motor Current and Static and Dynamic Contact Resistance tests.

- 16 contact inputs (optionally 24)** totally configurable. Each contact can be programmed as main breaker contact / PIR (Pre Insertion Resistor) or Auxiliary Contact. In this way it's possible to verify a breaker with up to 8 breaks per phase. If a contact is programmed as Main, it is provided the measurement of the time delay and optionally the value of the pre-insertion resistor (PIR).

- Two, four or six coil (Open / Close) commands** are available in order to control each phase (Open or Close) independently. Three different current ranges can be used to measure the coil current of each circuit.

- Up to three/six/nine micro-ohmmeters**, equipped with high current generators up to 200 A (each), are available in order to perform three phases static or dynamic resistance measurements of a breaker contact at the same time. Additional two micro-ohmmeters modules can be added to extend up to six or nine 200 A static or dynamic resistance measurements of breaker contacts.

- Safe test with Both Side Grounded:** CBA 3000 can perform Both Side Grounded test ( BSG ) of a breaker, measuring the main contacts timing even if both ends of the CB are connected to ground in order to enhance the safety.

- Eight analog input measurement circuits** totally configurable. Every input can be configured as :
  - generic AC or DC analog input up to 300V AC (or 420 V DC peak) for measuring standby battery or motor supply
  - low voltage measurement for motion analysis with transducers
  - low voltage measurement for pressure transducers
  - very low voltage measurement for current clamps with voltage output
  - very low voltage measurement for micro-ohmmeter function
  - generic voltage input for other purposes

- One auxiliary relay output**, programmable.

- Optional additional external micro-ohmmeter module** with three current generators up to 200 A to get up to 3 micro-ohmmeters . Up to two modules can be connected together in order to perform at the same time dynamic or static resistance measurements tests on a circuit breaker with up to three breaks per phase.

- Optional external thermal printer**, 112 mm paper wide.

- Optional internal thermal printer**, 58 mm paper wide.

- Optional Minimum Voltage Trip coil module** to verify the functionality of the coil commands circuitry when under voltage supplied.

- Optional IEC 61850-8 interface** for GOOSE publishing and subscription.

The **TDMS software test suite** is included: it allows analysing test results, adding notes, saving into a database, creating a test report. It allows also to store and recall Test Plans.

All circuits have been designed to ensure safe operation in the noisy environment of HV and MV substations.

The instrument is housed in a transportable aluminium box, that is provided with a cover and handles for ease of transportation.

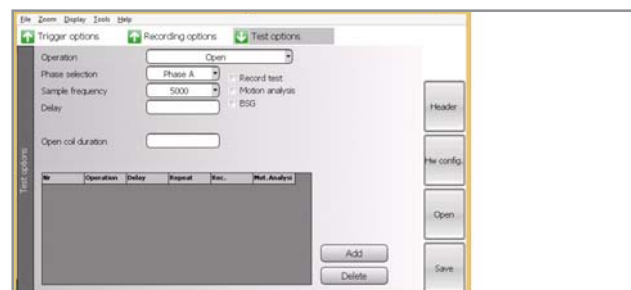

Test plan

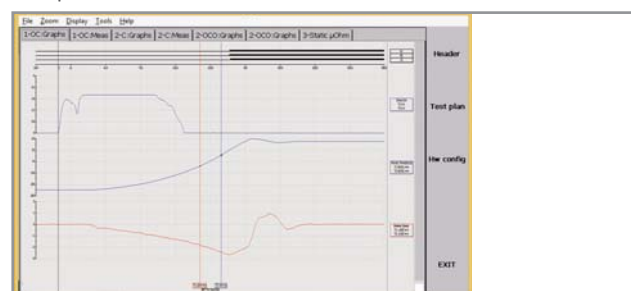

Test result

# F E A T U R E S

## • TIMING TEST

The following time measurement trigger options are user selectable:

- . Internal: the time measurement starts as the first Open or Close coil command is issued by the driving circuit. Timing accuracy:  $\pm 20 \mu\text{s}$ .
- . Coil current: the time measurement starts as soon as the first Open or Close coil current exceeds the selected current limit.
- . Auxiliary input: the time measurement starts when the selected auxiliary input turns ON or changes its state. The trigger can be performed also on a logical combination of auxiliary inputs.
- . Analog input: the time measurement starts when the analog input level crosses (greater than, lower than) the selected threshold.

## • PROGRAMMABLE SEQUENCES

The user can select the following single operations that can be all included in an unique test plan :

- . Open: the selected open coil phase is driven (all the combinations : all phases, phase1, phase 2, phase 3 , phase 1+2 , phase 2+3, phase 3+1)
- . Close: the selected close coil phase is driven (all the combinations as Open coil)
- . OC: In sequence, the Open and Close coils are driven. (all the combinations)
- . CO: In sequence, the Close and Open coils are driven. (all the combinations)
- . O-CO: In sequence, the Open, the Close and then again the Open coils are driven. The first Open command is issued on the selected Open coil phase, while the second Open command is issued on all coil phases.
- . Static resistance: the instrument performs a breaker resistance contact measurement using the available micro-ohmmeters on the selected phase (or on all the phases together).
- . Dynamic resistance: the instrument measures dynamically the resistance profile during an open or close operation: the result of the test will be a diagram and the breaker time delay based on the profile analysis.

These sequences are also selected by means of a dedicated pushbutton; the selected sequence is confirmed by an LED. For all the above sequences, the user can program the following time delays:

- . Open command duration: range 10 ms to 10 s.
- . Close command duration: range 10 ms to 10 s.
- . Open to Close delay: delay range 10 ms to 199.990 s.
- . Close to Open delay: delay range 10 ms to 199.990 s.
- . Dynamic open or close : range from 30 ms to 1 s
- . Recording duration: range 10 ms to 199.990 s.

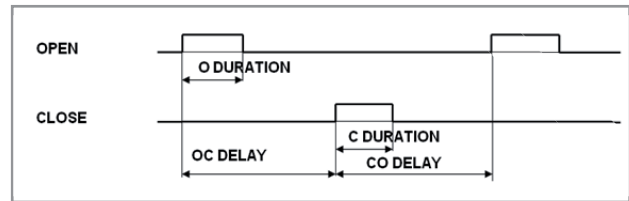

## • COIL CURRENTS

CBA 3000 calculates internally the maximum current of any coil command and at the meantime the current profile is recorded. The following figure shows the recording with an Open – Close command: delays are referred to coil commands.

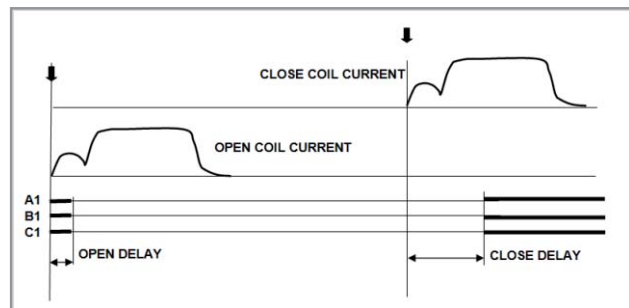

## • MOTION MEASUREMENTS

Using analog or digital transducers connected to the CBA 3000 inputs, it is possible to perform the motion analysis of a circuit breaker. All the typical measurements are executed, as speed, acceleration, overtravel and rebound.

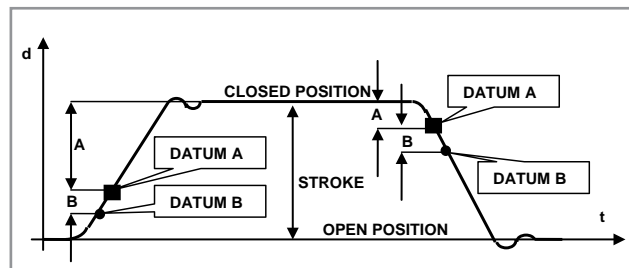

The breaker speed and acceleration are calculated between two datum points defined on the curve described by the transducer

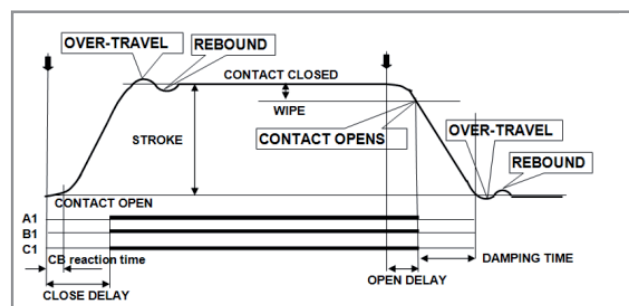





#### • STATIC RESISTANCE MEASUREMENT

This measurement is performed connecting CBA 3000 to the circuit breaker main contacts. Main contacts resistance is measured in the closed position.

##### Micro-ohmmeters and current generator:

- . Output current : 200A , 150 A, 100A , 50A, 25 A
- . Resistance measurement ranges: 250  $\mu$ Ohm, 1 mOhm, 10 mOhm, 50 mOhm
- . Minimum resolution: 0.5  $\mu$ Ohm
- . Contact resistance accuracy : 0.2% of the reading  $\pm$  0.2% of the range (for ranges 250 $\mu$ Ohm and 1mOhm)
- . Contact resistance accuracy : 0.3% of the reading  $\pm$  0.3% of the range (for ranges 10mOhm and 50mOhm)
- . Maximum test voltage: 5 V

#### • DYNAMIC RESISTANCE MEASUREMENT

With this measurement it is possible to record the main contact resistance during the CB Close or Open. The test current flows through the breaker contact and CBA 3000 measures the contact resistance variations during the close or open operation.

- . Test current, resistance ranges and other characteristics: as for the static resistance measurement.

#### • BOTH SIDE GROUNDED TESTS

Using the three micro-ohmmeters of CBA 3000 it is possible to perform breaker time delay tests even if Circuit Breaker both side are grounded.

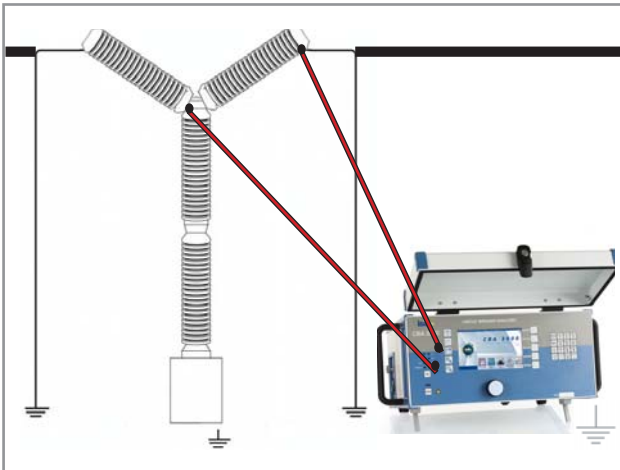

#### • FIRST TRIP TEST

Besides the standard off-line timing mode, CBA 3000 also features three-phase first trip test using optional AC or DC current clamps. The first time detection is important because, if the CB has been in service for a long period in close position, the first trip time can be considerably slow because of friction. In the normal test conduction, the circuit breaker is opened before connecting to the poles; so, the first movement friction is lost.

#### • TEST SET CONTROL

- . The local control is by keypad, selectors and display: no PC control is necessary.
- . Keypad: 16 keys (numeric and alphabet): it allows inputting all test references. The arrangement is the same as portable phones.
- . Two dedicated pushbuttons for test start and sequence selection.
- . Encoder with pushbutton for menu selection
- . Five dedicated keys for main functions as Load, Save etc. plus five pushbuttons that have different functions depending upon the active menu
- . The graphical display has the following main features:
  - Type: Color LCD;
  - Pixels: 800x 480;
  - View area: 152 x 92 mm;
- . Memory size: 256 Mbytes (approx. 1000 results).
- . Capability of saving and re-calling up to 256 Test Plans.

#### • DATA MANAGEMENT

The communication to the PC can be performed via two communication ports:

- . Ethernet and USB
- . Test results can be saved also into an USB pen memory: this allows transferring all test results to the office without the need of transporting the test set.

#### • ENHANCED TDMS SOFTWARE SUITE

The dedicated TDMS software has the following main features.

- . Download of test sequences.
- . Download of test results.
- . Test sequences and test results can be viewed, edited in the missing descriptions, saved, printed, exported.
- . Test data can be organized in a data base including all sub-station devices.
- . Possibility of viewing, overlaying and gluing more results, for an easy test result comparison.
- . Possibility to pre-set test sequences and to download them into the test set.
- . Two cursors to select measurement points and intervals.
- . Zoom in and out feature.
- . Pass – fail timing test result analysis.
- . Pass – fail current profile test result analysis.
- . Enhanced measurement features for movement – speed – acceleration control.

The software will be upgraded for free until a new version is released. Upgrading is simple: just connect to the ISA web site [www.isatest.com](http://www.isatest.com) and download the latest version. This applies also to the test set resident program.

#### • MENU DRIVEN

The menu is operated by means of the MENU control knob. Any setting can be saved and recalled from the internal memory, with a line of text description. At power-on, the default one is displayed: it can also be recalled as necessary. Settings are permanently stored in the memory. During the test, test results can be stored in the memory.

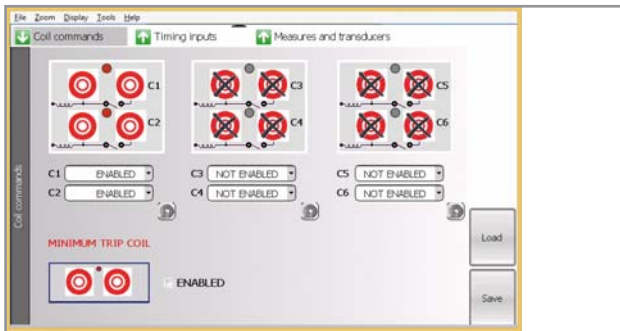

### AUXILIARY BINARY OUTPUT

- . One relay auxiliary output.
- . Characteristics of the contacts with a resistive load:  
AC: 300 V; 8 A; 2400 VA  
DC: 300 V; 8 A; 50 W
- . The contact operation can be timed with respect to test start.

### INPUTS TIME MEASUREMENT

- . Sample rate: from 10 Hz to 100 kHz maximum
- . Resolution: 0.01 ms to 100ms.
- . Inputs timing accuracy: see the following table.

RANGE s	FREQUENCY Hz	RESOLUTION ms	ACCURACY % of the reading
1	100.000	0.01	±0.02 ms ± 0.01%
2	50.000	0.02	±0.02 ms ± 0.01%
4	20.000	0.05	±0.05 ms ± 0.01%
10	10.000	0.1	±0.1 ms ± 0.01%
20	5000	0.2	±0.2 ms ± 0.01%
40	2000	0.5	0.5 ms ± 0.01%
100	1000	1	1 ms ± 0.01%

## TECHNICAL SPECIFICATION

### COIL COMMAND CIRCUITS

- . Number of circuits: 2, 4 or 6.
- . Type of driver: electronic; it ensures superior timing control.
- . Driver characteristic: 300 V DC max; 60 A DC max; 300 V AC max; 42 A AC max.
- . Operating time accuracy: 0.025% of delay ± 20 us.
- . Coil current ranges: 3 ; 10; 60 A full scale, user selectable.
- . Coil current measurement accuracy: 0.1% of the reading ± 0.1% of the selected range.
- . Outputs are isolated between them and between ground.

### TIMING CONTACT INPUTS (MAIN/PIR OR AUXILIARY)

- . Number of contact inputs: 16 (optionally 24), divided in 8 (optionally 12) groups of two each.
- . Each input group is isolated with respect to the others.
- . The contact inputs may be configured as main/PIR breaker contact or auxiliary contact.
- . The contacts status (closed or opened) are displayed on the screen

#### Main/PIR breaker contact

- . Test of the main contact and of the pre-insertion resistor contact, selectable.
- . PIR resistance range : 30 Ohm to 10 kOhm
- . PIR resistance measurement value (optional) accuracy : ± 2% of the reading ± 0.1% of the range.
- The contact is closed when the contact resistance is less than 10 Ohm.
- . Contact test voltage: 24 V; test current: 100 mA.

### AUXILIARY CONTACTS

- . Capability of testing dry contacts. Contact test voltage: 24 V; test current: 5 mA.
- . Capability of testing wet contacts. If wet, the input contact has these characteristics:
  - .. Voltage threshold : 15V / 77V or programmable with steps of 5V (for PIR resistance measurement value option) .
  - .. Impedance : >150kOhm or > 500 kOhm (for PIR resistance measurement value option)
- . Contact selection (dry or wet with thresholds) can be different on the groups.

### ANALOG INPUTS

- Number of analog inputs: 8, fully programmable.
- Common characteristics of analog inputs:
  - . Measurement resolution: 16 bit
  - . Number of ranges : three. 300Vac (420 Vdc peak) , 10Vdc, 1V DC
  - . Measurement accuracy:
    - 1 V range : ± 0.2% of the reading ± 0.2% of the range
    - 10 V range : ± 0.1% of the reading ± 0.01% of the range
    - 420 V range : ± 0.5% of the reading ± 0.1% of the range
  - . Input impedance: more than 600 kOhm.
  - . Measurement sampling rate: 100 kHz max.
  - . Number of insulated and independent neutrals: 4. Two groups of three channels each (to be used, for example, as transducer inputs for motion analysis and for voltage coming from micro-ohmmeter) and two different neutrals for the remaining two channels (for monitoring motor current or DC coil supply).
  - . Voltage value: + 5 V; maximum output current 30 mA; minimum transducer resistance 170 Ohm.
  - . Insulation between different neutrals : 1 kV AC.

### DIGITAL TRANSDUCER INPUTS

- CBA 3000 allows monitoring up to three digital transducers at the meantime.
  - . Maximum input frequency: 50 kHz
  - . Interface: RS422
  - . Accepted transducers: up to 5000 impulses per turn.
  - . Connection: by three multi-pole connectors used also for the analog inputs.





## OTHER CHARACTERISTICS

- . Mains supply:
  - .. From 85 to 265 V AC; 47-63 Hz
  - .. From 120 to 350 V DC.
- . Maximum supply current: 3.6 A @ 100 V AC or 1.8 A @ 200 V AC; maximum power consumption: 360 VA.
- . Housing: aluminium case, with hinged removable cover and handles.
- . Dimensions: 407 x 450 x 230 mm. Weight: 15 kg.
- The instrument comes complete with the following items:
  - . Mains cable
  - . User's manual
  - . Ethernet cable
  - ..USB cable
  - . One cable, yellow/green, for the connection to ground. Cable length: 4 m; cross section 1 sq. mm, terminated with a crocodile
  - . Spare fuses
  - .Software TDMS.

## APPLICABLE STANDARDS

The test set conforms to the EEC directives regarding Electromagnetic Compatibility and Low-Voltage instruments.

- . **Electromagnetic Compatibility:** Directive no. 2014/30/UE. Applicable Standard: EN61326-1:2013.
- . **Low Voltage Directive:** Directive n. 2014/35/UE. Applicable standards: CEI EN61010-1:2010. In particular:
  - . Input/output protection: IP 2X - IEC69529.
  - . Operating temperature: -10° to 55 °C; storage: -20 °C to 70 °C.
  - . Relative humidity: 5-95% without condensing.
- . **Vibration:** IEC 68-2-6 (20 m/s<sup>2</sup> at 10 – 150 Hz)
- . **Shock:** IEC 68-2-27 (15 g; 11 ms; half-sine)



## OPTIONAL ACCESSORIES

### ADDITIONAL COIL COMMANDS

With this option the test set is provided with the circuits to drive four or six coils (three Open, three Close). The option is made of one additional printed circuit board. Even if it is possible to upgrade CBA 3000, it is advisable to request the option at order.

### PIR

This option allows to measure the pre insertion resistance value of a main contact.

### MINIMUM VOLTAGE TRIP COIL TESTER

The option has the purpose of allowing to test the behaviour of the Minimum Trip Coil circuit and of Open or Close coils, when supplied at a reduced auxiliary voltage.

- . Voltage adjustment in steps of 1 V
- . Over-current protection
- . Max Voltage: 150 V.

### EXTERNAL PRINTER

Thermal printer, for the printout of all test results. Paper 112 mm wide.

### INTERNAL PRINTER

Integrated thermal printer, 58 mm wide, housed in the test set cover.

### 3 - CHANNEL MICRO-OHMMETER EXTERNAL MODULE

The external module contains three micro-ohmmeters equipped with high current generators up to 200 A (each), in order to perform 2 x three phases static or dynamic resistance measurements of a breaker contact at the same time. The module includes also three voltage inputs in order to measure the generated voltage, allowing in this way the resistance calculation.

Up to three modules can be connected together in order to perform at the same time dynamic or static resistance measurements tests on a circuit breaker with four breaks per phase. The option comes complete with the following connection cables:

- Three shielded cables for the measurement of the low voltage in micro-ohmmeter tests, including some conductors. Cable length: 10 m; cross section 0,5 sq. mm. Terminated with the suitable connector on the CBA 3000 side and with two clamps on the CB side.
- Six high current cables, made of one conductor. Cable length: 10 m; cross section 50 sq. mm. Terminated with a suitable connector on the CBA 3000 side and with an high current clamp on the CB side.
- Communication cable from CBA 3000 to the external micro-ohmmeter module.



## IEC 61850-8 PROTOCOL INTERFACE

The IEC 61850-8 Interface option for CBA 3000 allows:

- Publishing messages, assigning the selected GOOSE any binary output, and checking the system response.
- Subscribing messages, assigning data attributes to GOOSE messages and therefore validating the system.

This option is to be specified at order.

The Ethernet connector type RJ-45 for the IEC 61850 Interface is mounted directly on the interfaces panel of the CBA 3000.

## STANDARD TEST CABLE KIT

The basic connection cables set includes:

- Six cables with silicone sheath for the connection to the main contacts, each of three conductors. Cable length: 16 m.
- Two cables with silicone sheath for the connection to the auxiliary contacts, each of three conductors. Cable length: 6 m.
- Two cables with four conductors each, for the connection to the CB coils. Cable length: 10m.
- One shielded cable for the measurement of the low voltage in micro-ohmmeter tests. Cable length: 10 m.
- Two high current cables, made of one conductor. Cable length: 10 m.
- A set of 13 cables, 2 m long, of different colours.
- A set of adaptors from banana sockets to terminators, 20 in all, with different colours, for the auxiliary contacts and for the coil inputs.
- Four short cables, to put in common the coils supply.
- A cable for the MTC option
- Cables and adaptors for one analog and one digital transducers
- One set of 12 crocodiles, with different colours.
- One plastic case that hosts all the cables.

• For CBA 3000 with **24 configurable inputs option** provided, the following cables are also supplied:

- .. Three cables with sheath for the connection to the main contacts, each of three conductors. Cable length: 16 m.
- .. One cable with silicone sheath for the connection to the auxiliary contacts, each of three conductors. Cable length: 6 m.

• For CBA 3000 with **six coils option** provided, the following cables are also supplied:

- .. Two short cables, to put in common the coils supply
- .. One cable with four conductors each, for the connection to the CB coil. Cable length: 10m.

• For CBA 3000 with **three micro- ohmmeters option** provided, the following cables are also supplied:

- .. Two shielded cables for the measurement of the low voltage in micro-ohmmeter tests. Cable length: 10 m.
- .. Four high current cables, made of one conductor. Cable length: 10 m.

## LONG TEST CABLE KIT

Upon request, six cables with silicone isolator for the connection to the main contacts, each of three conductors, can be provided with a maximum length up to 38 m.



## TRANSIT CASE

The transit case allows delivering CBA 3000 with no concern about shocks up to a fall of 1 m and it provided with clasp removable cover. Protection degree: IP 60529.

## ANALOG TRANSDUCERS

### Analog transducers

We have a set of analog transducers, linear and rotating. Linear transducers have different strokes, and also different IP protections: low for the TLH series, high for the LWG series. A mounting kit is also available. The table summarizes characteristics.

TYPE	DESCRIPTION	STROKE mm / °
linear	TLH 150	150
linear	TLH 225	225
linear	TLH 300	300
linear	TLH 500	500
linear	LWG 150	150
linear	LWG 225	225
linear	LWG 500	500
linear	LWG 750	750
analog rotary	IP 6501	355°

The mounting kit includes the following materials:

- . N. 1 Magnetic support
- . N. 1 Adaptive arm
- . N. 1 Small mechanical clamp
- . N. 1 Big mechanical clamp
- . N. 1 Support for the rotating transducer
- . N. 1 Connection cable, 10 m long
- . N. 1 Rotary transducer (or linear transducer, or both).

The kit is included into a plastic transport case.





Rotary Transducer



LWG Linear Transducer

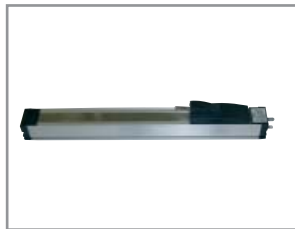

TLH Linear Transducer



Transducers Mounting Kit

- . Measurement errors: 4% of reading + 20 mA for the 80 A range; 2% of reading + 5 mA for the 2 A range.
- . Phase shift (up to 65 Hz): maximum 1°.
- . Maximum working voltage: 600 V rms.
- . Power supply: alkaline 9 V battery, type 6 LR 61.
- . Service life: 70 h typical.
- . Maximum cable diameter: 10 mm.
- . Weight: 330 g.
- . Dimensions: 65 mm wide (clamp closed); 36 mm thick; 230 mm long.



Hall effect clamp

## DIGITAL TRANSDUCERS

The digital transducer option has the following characteristics.

- . Transducer name: HENGSTLER RS0-550-170
  - . Transducer type: RS422 interface; 5000 impulses per turn
  - . Connection: the transducer is connected to the test set via a shielded cable, 10 m long, terminated with a connector.
- The mounting kit is the same as above.

## PRESSURE TRANSDUCER

The KELLER pressure transducer type PA-21Y/40bar/81554.33 allows monitoring the variation of the SF6 pressure while the circuit breaker is operated. Main characteristics:

- . Pressure range: 0 to 40 bar (pressure differential with respect to 1 bar of the atmospheric pressure);
- . Supply voltage: 8 to 32 V DC;
- . Output voltage: 0 to 5 V DC. 0 V at the atmospheric pressure, 5 V at the absolute pressure of 41 bar;
- . Linearity error: maximum 0.5% of the range;
- . Total error, 0 to 50 °C: maximum 1% of the range.

## HALL EFFECT CLIP-ON TRANSFORMER FOR DC CURRENT MEASUREMENTS

The Hall effect clip-on transformer allows measuring the DC current of motors and of the auxiliary supply. Main characteristics:

- . Metering: AC and DC currents.
- . DC measurement null with a knob.
- . Ranges: 10 mV/A, 80 A DC, 40 A AC maximum, and 1 V/A, 2 A DC, 1.5 A AC maximum.
- . Low battery indicator.

## AC CURRENT CLAMP FOR FIRST TRIP TEST

The current clamp allows performing the first trip test: for three phase testing, three of them are necessary. The clamp ratio is 1 A/0.1 V; maximum primary current 10 A; maximum cable diameter 12 mm.

## ORDERING INFORMATION

CODE	MODULE
20178	CBA 3000 - with TDMS software 16 Configurable Main / Auxiliary inputs One ( 1 ) 200 A DC Microhmmeter 8 configurable Analog inputs 2 Coil commands ( Open / Close)
26178	Test cable kit with transport case
58178	Microhmmeter cable kit
21178	CBA 3000 - with TDMS software 24 Configurable Main / Auxiliary inputs One ( 1 ) 200 A DC Microhmmeter 8 configurable Analog inputs 4 Coil commands ( Open / Close)
27178	Test cable kit with transport case
58178	Microhmmeters cable kit
22178	CBA 3000 - with TDMS software 24 Configurable Main / Auxiliary inputs Three ( 3 ) 200 A DC Microhmmeters 8 configurable Analog inputs 4 Coil commands ( Open / Close) Both Side Grounded function
27178	Test cable kit with transport case
58178 (3)	Microhmmeter cable kit
23178	CBA 3000 - with TDMS software 24 Configurable Main / Auxiliary inputs Three ( 3 ) 200 A DC Microhmmeters 8 configurable Analog inputs 6 Coil commands ( Open / Close) Both Sides Grounded function
29178	Test cable kit with transport case
58178 (3)	Microhmmeters cable kit

## OPTIONS

CODE	MODULE
26178	CBA 3000 ( 16 Inputs - 4 coil command configuration) test cable kit with transport case
27178	CBA3000 ( 24 Inputs- 4 coil command configuration) test cable kit with transport case
29178	CBA3000 ( 24 Inputs- 6 coil command configuration) test cable kit with transport case
58178	1 Microhmmeter cable kit
60178	Additional 2 Coils Command (Open / Close)
61178	Additional 8 Inputs Main-PIR/ Auxiliary
62178	Additional 8 Inputs Main -PIR / Auxiliary with Pre-Insertion Resistor value measurement
63178	Additional Two ( 2 ) 200 A D Microhmmeters and BSG ( Both Sides Grounded ) function
59178	IEC61850-8 Protocol Interface - Goose
37178	MTC - Minimum trip coil test module
64178	External thermal printer
65178	Internal thermal printer
57178	Heavy duty transport case
11166	TLH 150 Analog Linear Transducer 150 mm
12166	TLH 225 Analog Linear Transducer 225 mm
36166	TLH 300 Analog Linear Transducer 300 mm
13166	TLH 500 Analog Linear Transducer 500 mm
14166	Analog Rotary Transducer: IP 6501 – 355° rotation angle
26166	LWG 150 Analog Linear Transducer 150 mm
27166	LWG 225 Analog Linear Transducer 225 mm
28166	LWG 500 Analog Linear Transducer 500 mm
42166	LWG750 linear transducer 750 mm
11169	Digital Rotary Transducer Hengstler RSO-550-170
35178	Pressure transmitter PA-21Y 40BAR
33178	Universal analogic mounting kit
34178	Digital transducer mounting kit
88169	Current clamp for First Trip test
29166	Hall effect clip-on transformer
44166	Flexible shaft coupler



**isa**  
we.know.how.



I.S.A. srl - via Prati Bassi 22  
21020 Taino (VA) ITALY  
T +39 0331 956081 - F +39 0331 957091

isa@isatest.com  
www.isatest.com