

Altanova Global Tap Adapter Kit

Global Tap Adapter Kit



Techimp Voltage Tap Adapter is gender changer which allows the user to connect to the test tap (or power factor tap) of high voltage transformer bushings.

While keeping the test tap well below the safety voltage level required by the manufacturer, the Tap Adapter lets the user to drain high frequency PD signals for diagnostic assessment of insulating materials.

A synchronization signal can be derived as well.

It is mostly suitable for spot measurement, while for continuous PD monitoring an outdoor version should be used.

Several thousands of hours of operation are a guarantee of reliability and accurate design.

The below list reports the mechanical thread and the bushing manufacturer, although others might be compatible as well.



Description	Bushing manufacturer	Qty
Tap Adapter 1" 1_8 - 12 UNF	Passoni&Villa or similar	1
Tap Adapter M24x1.5	ABB HSP or similar	1
Tap Adapter M30x1.5	ABB HSP or similar	1
Tap Adapter M30x2	ABB or similar	1
Tap Adapter 2" 1_4 - 12 UNF	ABB GOE / OHIO BRASS / P-CORE or similar	1
Tap Adapter M16x1,5	Trench or similar	1
Tap Adapter M16x2	ABB GOB or similar	1
Tap Adapter 1" 1_2 - 6 UNC	Mitsubishi or similar	1
PQ STANDARD Resistive 100ohm		1
Silicone cable, red, terminated with banana and eye lug, 2m		1
Silicone cable, black, terminated with banana and eye lug, 2m		1

*Please note: in order to ensure full compatibility, the customer must refer to the mechanical thread listed above instead of bushing manufacturer. Techimp – Altanova Group Srl will not therefore be responsible for any type of incompatibility.

Altanova Global Tap Adapter Kit

Mechanical Specifications

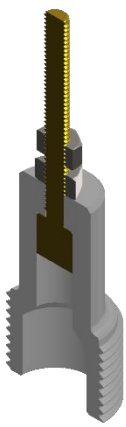

1" 1/8 - 12 UNF

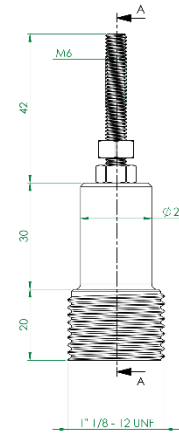
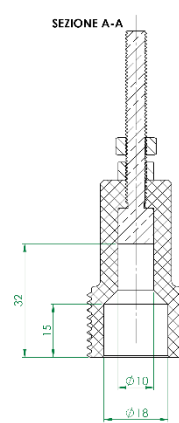

M16x1.5

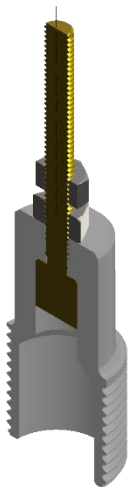
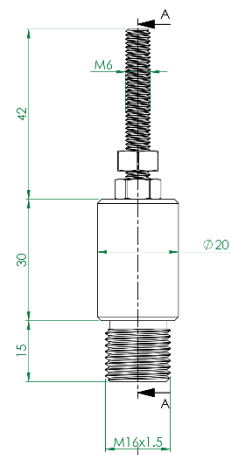
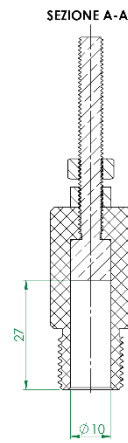

M24x1.5

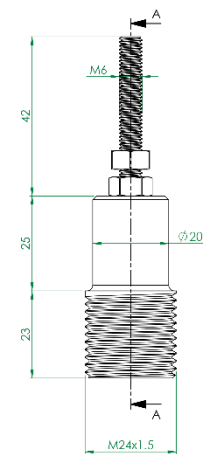
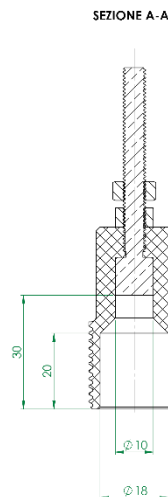

Altanova Global Tap Adapter Kit

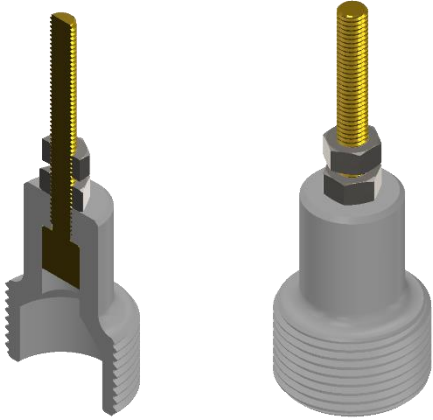

M30x1.5

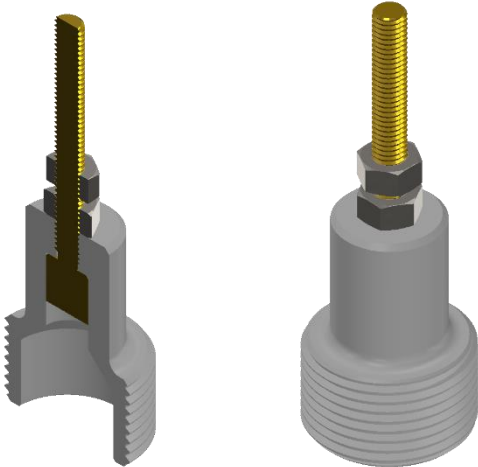
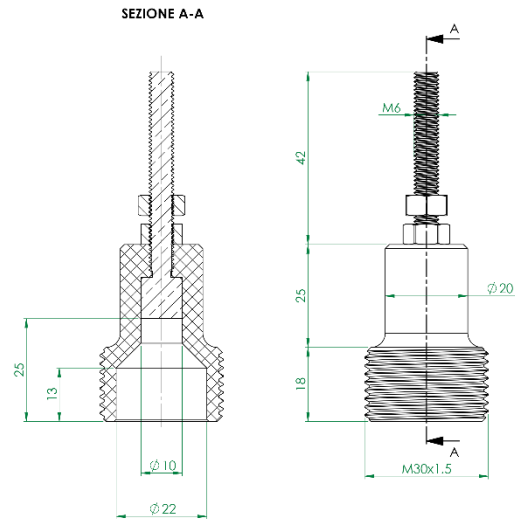

M30x2

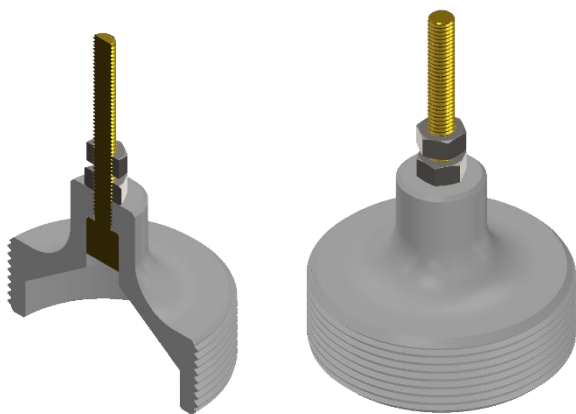
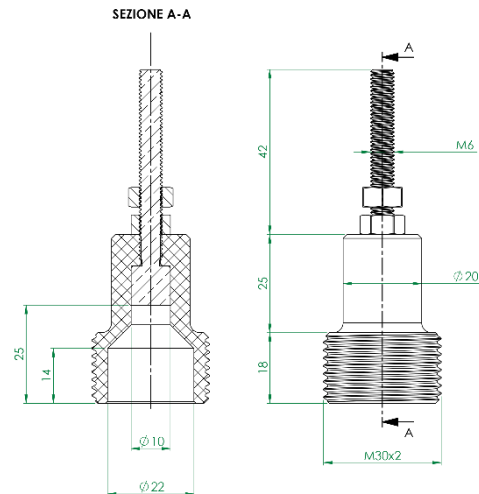

2" 1/4 - 12 UNF

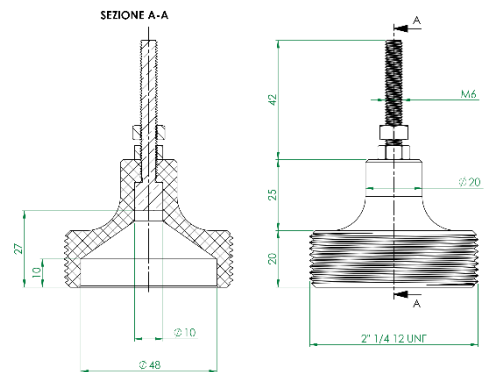

Altanova Global Tap Adapter Kit

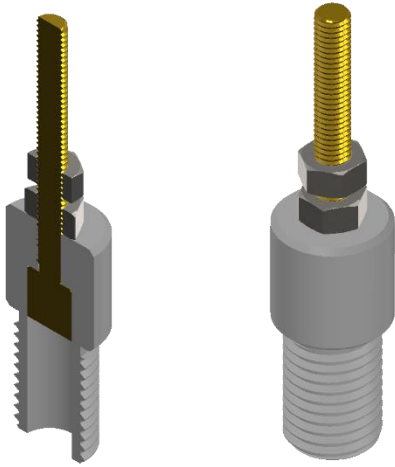

M16x2

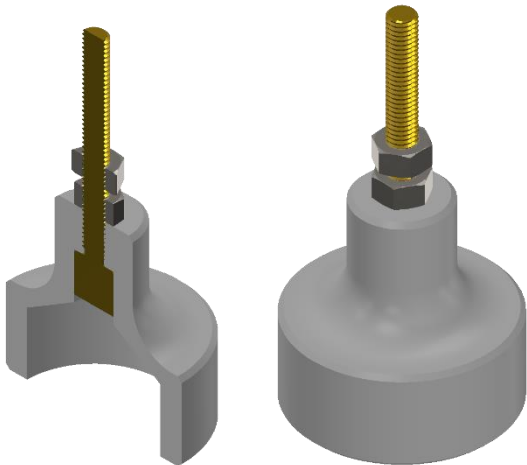
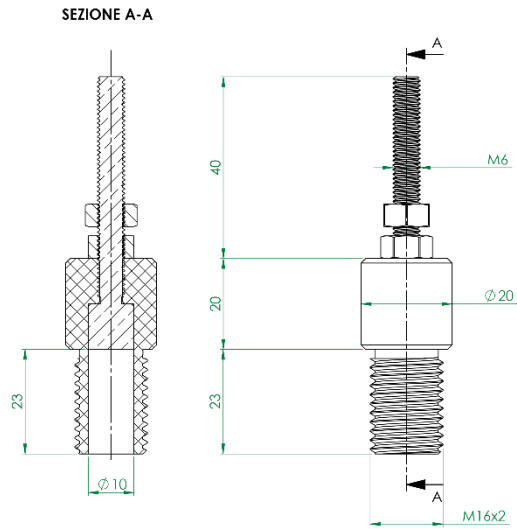

1" 1/2 - 6 UNC

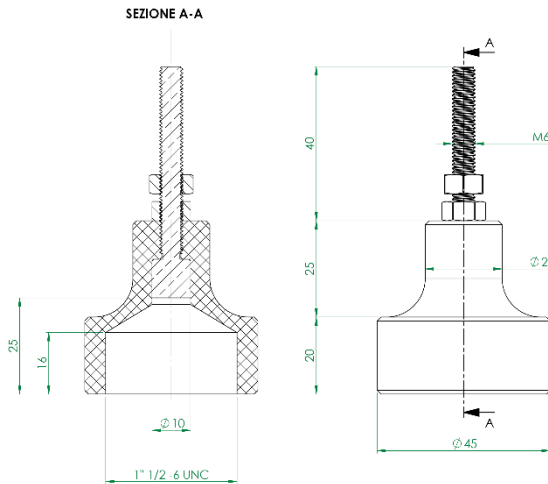

ALTANOVA

GROUP

www.altanova-group.com

TECHIMP

TECHIMP - ALTANOVA GROUP
Via Toscana 11,
40069 Zola Predosa (Bo) - Italy
T +39 051 199 86 050
Email sales@altanova-group.com

isa

ISA - ALTANOVA GROUP
Via Prati Bassi 22,
21020 Taino (Va) - Italy
T +39 0331 95 60 81
Email isa@altanova-group.com

IntelliSAW

intelliSAW - ALTANOVA GROUP
100 Burt Rd
Andover, MA 01810, USA
T +1 978-409-1534
Email contact@intellisaw.com