

high performance coupling capacitors

TCC 07 1nf

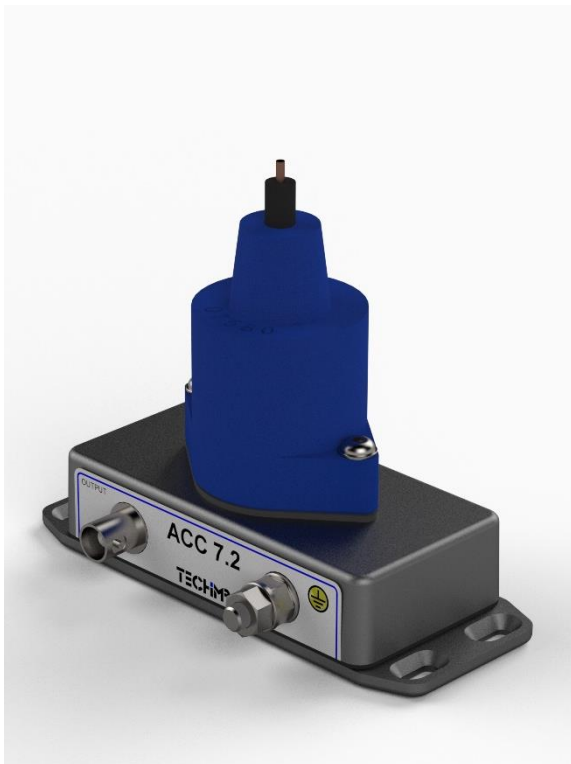

TCC07 are capacitive couplers specifically designed for partial discharge measurements. Its extremely compact size makes it a good choice for on line and off line PD tests on rotating machines, for both spot measurements and permanent monitoring applications. It can be permanently installed in terminal boxes of AC power generators as well as in power supply boxes of critical power motors or inside MV bus ducts. A BNC output termination is available on the base. For permanent installation it must be fixed through 4 holes on the bottom flange. ACC07 coupler contains an internal resistor which provides a suitable dividing ratio @50Hz (as well as 60Hz) for those equipment which require a synchronization signal. It also holds an internal overvoltage gas suppressor which keeps the output voltage below safety limits even in the presence of spikes and overvoltage transient peak on the bus bars. ACC07 couplers are individually tested according to the following international standards: IEC60358; IEC60694; IEC60270 Tested at high vibration level in order to assure high reliability under the most severe conditions. It can be installed in vertical position, upside down in and horizontal position. Endurance voltage test showed an expected life (at rated voltage) in excess of 106 hours, i.e. larger than the expected life of any device it should be matched to.

Specifications

Capacitance	1100 pF \pm 20%
High voltage frequency range	50÷60 Hz
Rated Voltage (phase-to-phase)	7 kVrms
VOUT @ Rated voltage	1.1 VRMS
High pass cut frequency (-6dB)	150 kHz
AC voltage withstand	20 kVrms
DC voltage withstand	45 kVpeak
Lightning pulse withstand	65 kVpeak
Creepage distance (IEC60815)	>140 mm (medium level pollution)
Tan δ	< 1.0 %
PD level @8kV / 50Hz	<5 pC

TCC 07 1nf

Overall Dimensions

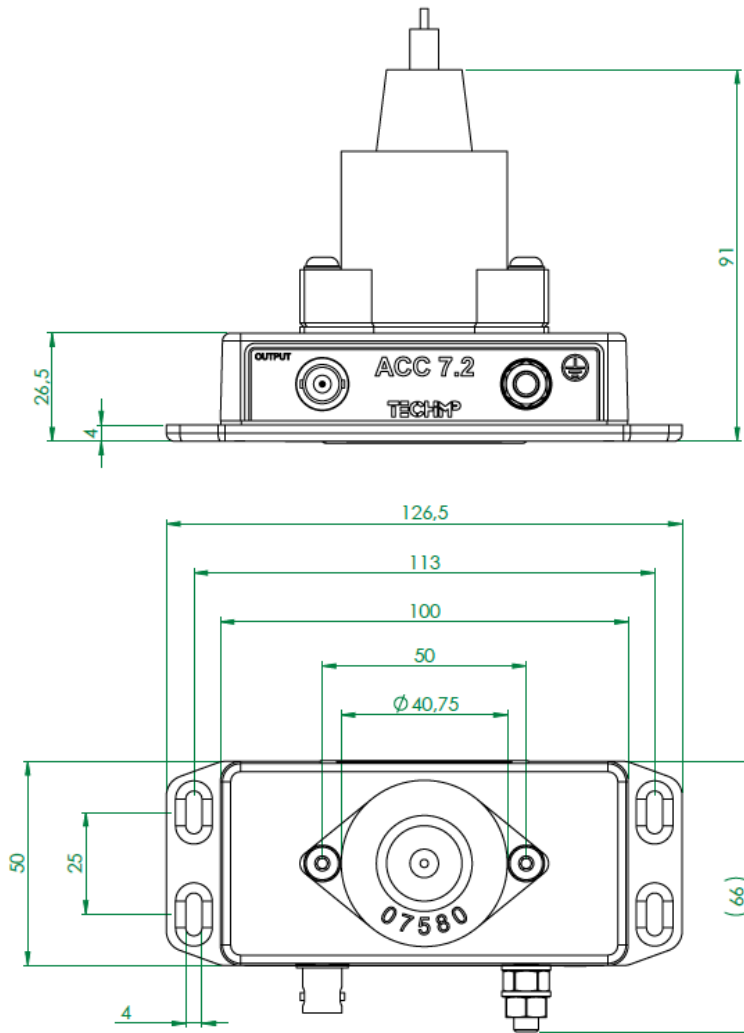

 Suitable For

MOTOR	GENERATOR	PWM VSD	MV SWITCH GEAR	MV TRAFO
-------	-----------	---------	----------------	----------

Several different sensors are available, fully compatible with Techimp Global Diagnostic platform. They can be freely combined at customer needs provided they can be applied for the specific application.

TCC 07 DATA SHEET [ENG] - REV.20200324

ALTANOVA
GROUP
www.altanova-group.com

TECHIMP
TECHIMP - ALTANOVA GROUP
Via Toscana 11,
40069 Zola Predosa (Bo) - Italy
T +39 051 199 86 050
Email sales@altanova-group.com

isa
ISA - ALTANOVA GROUP
Via Prati Bassi 22,
21020 Taino (Va) - Italy
T +39 0331 95 60 81
Email isa@altanova-group.com

intelliSAW
intelliSAW - ALTANOVA GROUP
100 Burrtr Rd
Andover, MA 01810, USA
T +1 978-409-1534
Email contact@intellisaw.com